

**supervac**<sup>®</sup>

intelligent vacuum packaging



## Supervac GK 125 Table-top Vacuum Packaging Machine

- All stainless steel construction.
- Transparent lid.
- Soft ventilation programmable.
- Microprocessor control with vacuum sensor.
- Integral vacuum pump with motor protection.

## GK 125

- Reliable and easy to service.
- Hygienic design - easy to clean.
- Simple to operate.

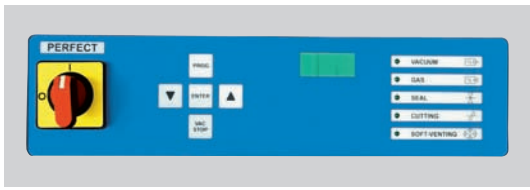

## GK 125 Compact and Reliable

### GK 125 Electronic Control.

- Microprocessor control with vacuum sensor.
- User friendly flat keyboard.
- 10 programme memory.
- Evaporation point detection.
- Digital display of machine functions.
- Quick-Stop button.
- Soft ventilation programmable.
- Service programme for dehumidifying the integral Busch vacuum pump.
- Oil change display.

Vacuum packaging of perishable food – fresh and processed meat, sausages, fish, cheese, prepared dishes and more – no loss of weight, longer shelf life.

### Standard Feature:

- Single sealing + Hot wire cut off.

### Optional Feature:

- Gas flushing (2 gas nozzles) for fragile products.

#### Technical Data:

Outside dimensions .....	480 x 655 x 385 mm (18.9 x 25.8 x 15.1")
Chamber dimensions .....	430 x 505 x max. 175 mm (16.9 x 19.9 x 6.9")
Seal bar length .....	405 mm (15.9")
Maximum product length .....	455 mm (17.9")
Integral Busch vacuum pump .....	21 m <sup>3</sup> /h
Mains connection .....	230V, 1Ph, 50Hz / 60Hz
	110 – 120V, 1Ph, 60Hz
Weight approx. ....	65 kg

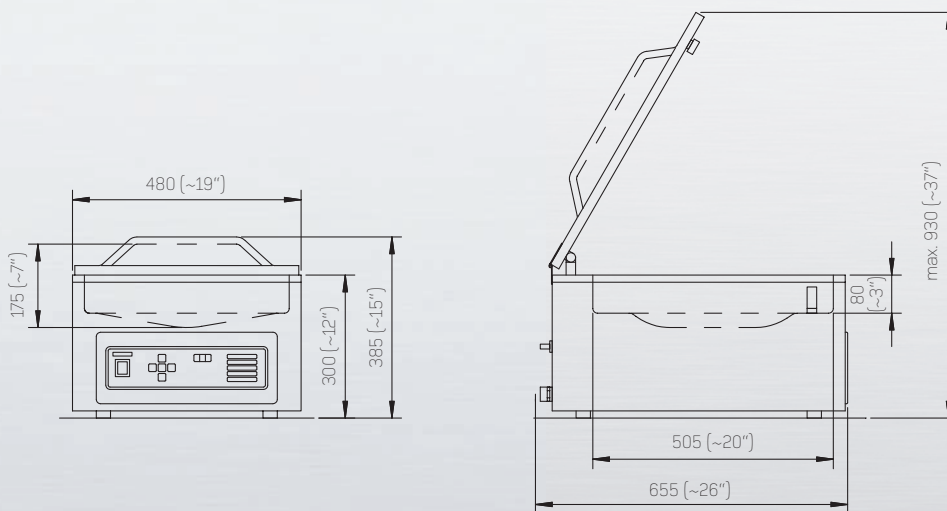

Subject to change without notice.

Copyright © 2012 Supervac Ges.m.b.H. All rights reserved.  
03/2013 | Supervac is a registered trademark of Supervac Ges.m.b.H.